

**Code:**

9RN	NN	M	O	CC	CC
-----	----	---	---	----	----

9RN	Flow Divider Typology
NN	Number of flow divider elements
M	Code of setting range of the valves
O	Number of motor elements
CC	Motor Displacement Code
CC	Flow Divider Displacement Code

TABLE "M"	
C	10 ÷ 105 bar
D	70 ÷ 210 bar
E	140 ÷ 350 bar

**Example:** Flow divider with two elements (same displacement) and Motor RV-1H / 3,8 x 2 with valve 10 ÷ 105 bar + 1 motor 7,8

9RH	02	C	1	34	25
-----	----	---	---	----	----

**Example:** Flow Divider 3 elements (different displacement - max 6) and Motor: RV-1H / 3,8+4,9+4,9 with valve 70 ÷ 210 bar + 1 Motor 6.5

9RH	03	D	1	32	25	29	29
-----	----	---	---	----	----	----	----

**NOTE:** to define codes for flow dividers with more than 6 different displacement, please contact our sales department.

**Table: 1**

Displacem. Cm <sup>3</sup> /rev	CC Code	Max Pressure bar	One element flow rate l/min		
			MIN	RECOMMENDED	
0,9	16	220	1	2	6
1,2	17	220	1,5	3	7
1,7	18	220	2	4	9
2,2	20	220	2,5	5	13
2,6	21	220	3	6	15,5
3,2	23	220	3,5	7,5	18
3,8	25	220	4	8,5	21
4,3	27	220	4,5	9,5	23
4,9	29	220	5,5	11	27
5,9	31	220	6,5	13	30
6,5	32	220	7,5	14	32
7,8	34	210	8,5	16	35,5
9,8	36	200	11	20	41

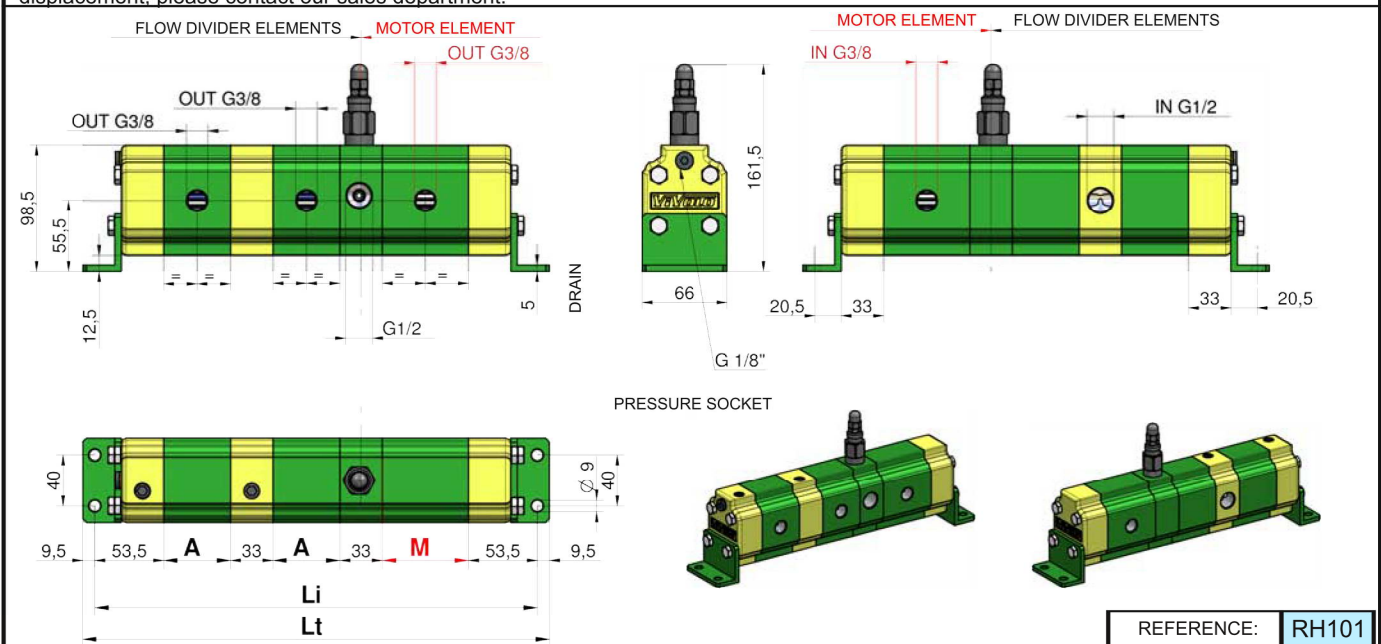

**Table: 2**

**Li = Distance between fixing hole centres (single displacement flow divider)**

Cm <sup>3</sup> /rev	A-M	Number of elements														
		2	3	4	5	6	7	8	9	10	11	12	13	14	15	16
0,9	41,5	223	297,5	372	446,5	521	595,5	670	744,5	819	893,5	968	1042,5	1117	1191,5	1266
1,2	42,5	225	300,5	376	451,5	527	602,5	678	753,5	829	904,5	980	1055,5	1131	1206,5	1282
1,7	44	228	305	382	459	536	613	690	767	844	921	998	1075	1152	1229	1306
2,2	46	232	311	390	469	548	627	706	785	864	943	1022	1101	1180	1259	1338
2,6	48	236	317	398	479	560	641	722	803	884	965	1046	1127	1208	1289	1370
3,2	50	240	323	406	489	572	655	738	821	904	987	1070	1153	1236	1319	1402
3,8	52	244	329	414	499	584	669	754	839	924	1009	1094	1179	1264	1349	1434
4,3	54	248	335	422	509	596	683	770	857	944	1031	1118	1205	1292	1379	1466
4,9	57	254	344	434	524	614	704	794	884	974	1064	1154	1244	1334	1424	1514
5,9	60,5	261	354,5	448	541,5	635	728,5	822	915,5	1009	1103	1196	1289,5	1383	1476,5	1570
6,5	63	266	362	458	554	650	746	842	938	1034	1130	1226	1322	1418	1514	1610
7,8	67	274	374	474	574	674	774	874	974	1074	1174	1274	1374	1474	1574	1674
9,8	76	292	401	510	619	728	837	946	1055	1164	1273	1382	1491	1600	1709	1818

**Table: 3** in this table the number of inlets in function of the number of elements are indicated.

Number of elements	2	3	4	5	6	7	8	9	10	11	12	13	14	15	16
"IN" Number of inlets	1	1	2	2	3	3	4	4	5	5	6	6	7	7	8

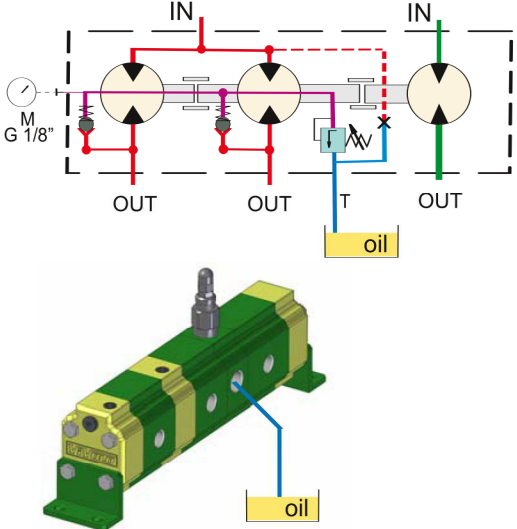
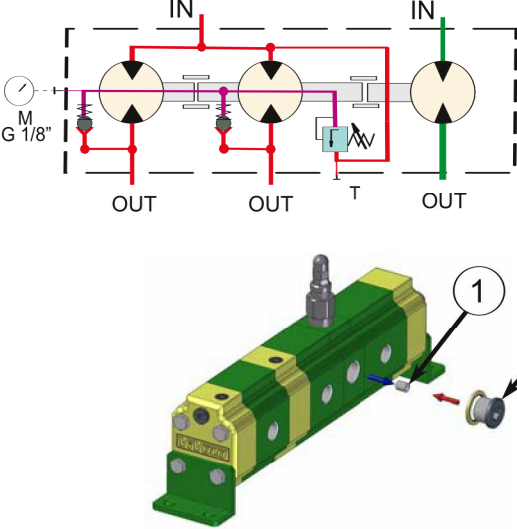
EXTERNAL DRAIN <i>STANDARD SETUP</i>	INTERNAL DRAIN
<p>Connect the drain port (T) to the tank</p>	<p>To predispose the divider to the internal drain, execute following operations:</p> <ol style="list-style-type: none"> <li>1. remove the G 1/8 dowel inside the drain port</li> <li>2. with a 1/2 G plug, plug the drain port (T)</li> </ol>
	

In **table 1** the functioning range of single flow divider elements is indicated.

The higher is the feeding capacity ( q ), the higher is the precision of the flow division, but in opposition there are losses of loading and higher noise. Therefore we suggest to feed the elements with capacities equal or a few superior to the ones indicated in the column **"RECOMMENDED"**.

Remember to verify the capacities even in phase of flow reunion.

The pressure indicated are to be considered as maximum of functioning, the flow divider is able to bear peaks of pressure 20 % superior.

**How to calculate the "Li" and "Lt" measures of flow dividers:**

From **table 2** it is possible to obtain the "Li" measure for flow dividers up to 16 elements with equal displacements; for flow dividers with different elements or with more than 16 elements the "Li" and "L" measure have to be calculated by the following formula:

$$Li = [(n-1) \times 33] + 107 + (A1 + A2 + A3 + \dots)$$

$$107 = 53,5 + 53,5$$

n = Number of elements of flow divider

A1... An = heights of elements of flow divider

$$Lt = Li + 19$$

$$19 = 9,5 + 9,5$$

**EXAMPLE:** To obtain the measures Li and Lt of a flow divider with three elements (n=3), **RV-1H / 3,8 x 2+ 1 Motor 7,8 cc**

Distance between fixing hole centres

$$Li = [(3-1) \times 33] + 107 + 52 + 52 + 67 = 344 \text{ mm}$$

Total Length

$$Lt = 344 + 19 = 363$$

In **table 3** the number of inlets in function of the number of elements are indicated.

For flow dividers with many inlets, as they are all communicating it is even possible to use only one of them, by plugging the other ones. We suggest to make full us at least of **1** inlet every **40 l/min** capacity.

To obtain errors of division **inferior to 3%** there must be no difference of pressure between the elements superior to **30 bar**. To obtain high precisions the respect of the following parametres is also important:

- Environment temperature: -10°C ÷ +60°C      Oil temperature: +30°C ÷ +60°C
- Hydraulic oil based on hlp, hv (din 51524) minerals      Oil Viscosity 20 ÷ 40 cSt
- Oil filtering 10 ÷ 25 µ

**Code:**

9RN	NN	M	O	CC	CC
-----	----	---	---	----	----

9RN	Flow Divider Typology
NN	Number of Flow Divider Elements
M	Code of setting range of the valves
O	Number of motor elements
CM	Motor displacement code
CC	Flow Divider displacement code

TABLE "M"	
C	10 ÷ 105 bar
D	70 ÷ 210 bar
E	140 ÷ 350 bar

**Example:** Flow divider with two elements (same displacement) and Motor RV-1H / 7,8 x 2 with valve 10 ÷ 105 bar + 1 Motor 17

9RH	02	C	1	51	34
-----	----	---	---	----	----

**Example:** Flow Divider 3 elements (different displacement - max 6) and Motor: RV-1H / 3,8+4,9+4,9 with valve 70 ÷ 210 bar + 1 motor 14

9RH	03	D	1	49	25	29	29
-----	----	---	---	----	----	----	----

**NOTE:** to define codes for flow dividers with more than 6 different displacement, please contact our sales department.

**Table: 1**

Displacem. Cm <sup>3</sup> /rev	CC Code	Max Pressure bar	One element flow rate l/min		
			MIN	RECOMMENDED	MAX
0,9	16	220	1	2	6
1,2	17	220	1,5	3	7
1,7	18	220	2	4	9
2,2	20	220	2,5	5	13
2,6	21	220	3	6	15,5
3,2	23	220	3,5	7,5	18
3,8	25	220	4	8,5	21
4,3	27	220	4,5	9,5	23
4,9	29	220	5,5	11	27
5,9	31	220	6,5	13	30
6,5	32	220	7,5	14	32
7,8	34	210	8,5	16	35,5
9,8	36	200	11	20	41

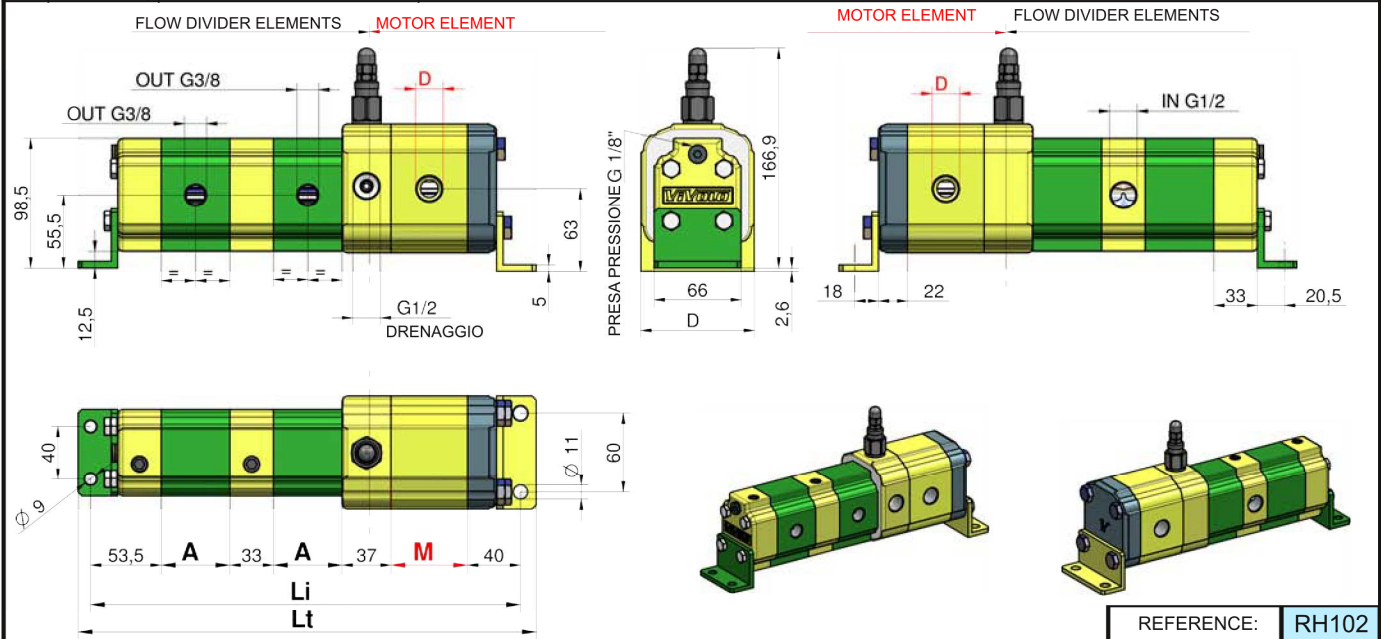

REFERENCE: RH102

Cm <sup>3</sup> /rev	A
0,9	41,5
1,2	42,5
1,7	44
2,2	46
2,6	48
3,2	50
3,8	52
4,3	54
4,9	57
5,9	60,5
6,5	63
7,8	67
9,8	76

Cm <sup>3</sup> /rev	CM	M	D
4	41	47	1/2" BSP
6	43	50	1/2" BSP
9	45	54	1/2" BSP
11	47	58	1/2" BSP
14	49	64	3/4" BSP
17	51	68	3/4" BSP
19	53	72	3/4" BSP
22	55	78	3/4" BSP
26	57	82	1" BSP
30	59	90	1" BSP
34	61	97	1" BSP
40	63	106	1" BSP

**Table: 3** in this table the number of inlets in function of the number of elements are indicated.

Number of elements	2	3	4	5	6	7	8	9	10	11	12	13	14	15	16
"IN" Number of inlets	1	1	2	2	3	3	4	4	5	5	6	6	7	7	8

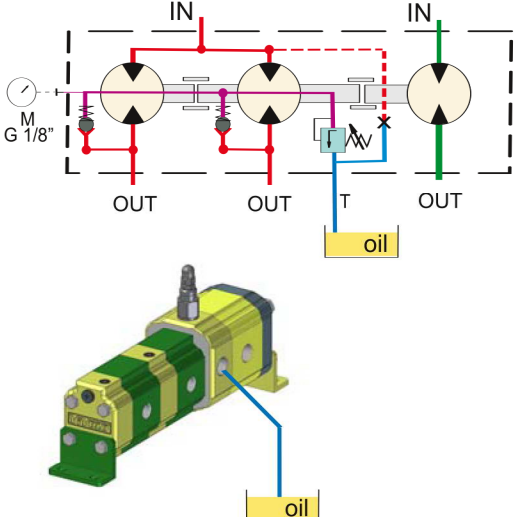
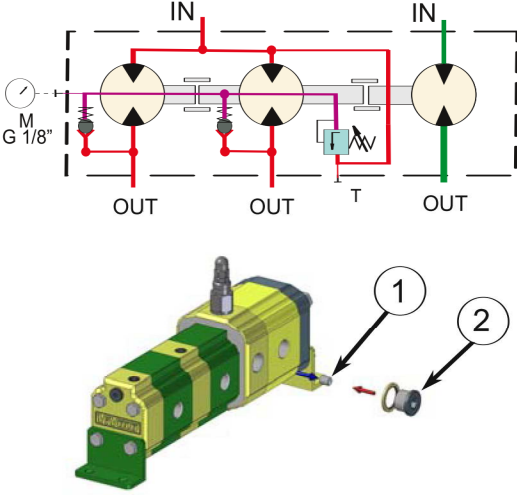

EXTERNAL DRAIN <i>STANDARD SETUP</i>	INTERNAL DRAIN
<p>Connect the drain port (T) to the tank</p>	<p>To predispose the divider to the internal drain, execute following operations:</p> <ol style="list-style-type: none"> <li>1. remove the G 1/8 dowel inside the drain port</li> <li>2. with a 1/2 G plug, plug the drain port (T)</li> </ol>
	

In **table 1** the functioning range of single flow divider elements is indicated.

The higher is the feeding capacity ( q ), the higher is the precision of the flow division, but in opposition there are losses of loading and higher noise. Therefore we suggest to feed the elements with capacities equal or a few superior to the ones indicated in the column "**RECOMMENDED**".

Remember to verify the capacities even in phase of flow reunion.

The pressure indicated are to be considered as maximum of functioning, the flow divider is able to bear peaks of pressure 20 % superior.

**How to calculate the "Li" and "Lt" measures of flow dividers:**

$$Li = [(n-1) \times 33] + 130,5 + (M1 + M2 + M3 + \dots) + (A1 + A2 + A3 + \dots)$$

$$Lt = Li + 21,5$$

$$130,5 = 53,5 + 37 + 40$$

**n** = Number of elements of flow divider

**A1... An** = heights of elements of flow divider

**M1... Mn** = heights of motor elements

$$21,5 = 9,5 + 12$$

**EXAMPLE:** To obtain the measures Li and Lt of a flow divider with three elements (n=2) **RV-1H / 3,8 x 2 + 1 Motor 11**

Distance between fixing hole centres

$$Li = [(2-1) \times 33] + 130,5 + 47 + 52 + 52 = 314,5 \text{ mm}$$

Total Length

$$Lt = 314,5 + 21,5 = 336$$

In **table 3** the number of inlets in fuction of the number of elements are indicated.

For flow dividers with many inlets, as they are all communicating it is even possible to use only one of them, by plugging the other ones. We suggest to make full us at least of **1** inlet every **40 l/min** capacity.

To obtain errors of division **inferior to 3%** there must be no difference of pressure between the elements superior to **30 bar**. To obtain high precisions the respect of the following parametres is also important:

- Environment temperature: -10°C ÷ +60°C      Oil temperature: +30°C ÷ +60°C
- Hydraulic oil based on hlp, hv (din 51524) minerals      Oil Viscosity 20 ÷ 40 cSt
- Oil filtering 10 ÷ 25 μ