

Flow divider with independent phase correction and anticavitation valves for each element

Code:

9RV NN M CC

9RV	Flow Divider Typology
NN	Number of elements
M	Code of setting range of the valves
CC	Displacement Code

TABLE "M"	
A	7 ÷ 70 bar
B	35 ÷ 175 bar
C	70 ÷ 350 bar

Example: Flow divider with two elements (same displacement)
RV-0V / 0,57 x 2 with valve 7 ÷ 70 bar

9RV 02 A 05

Example: Flow Divider with 4 elements (with different displacement - max 7):
RV-0V / 0,57+0,76+0,98+1,52 with valve 35 ÷ 175 bar

9RV 04 B 05 06 07 11

NOTE: to define codes for flow dividers with more than 7 different displacement, please contact our sales department.

Table: 1

Displacem. Cm ³ /rev	CC Code	Max Pressure bar	One element flow rate l/min		
			MIN	RECOMMENDED	MAX
0,17	01	210	0,2	0,4	1,2
0,25	02	210	0,3	0,7	1,8
0,45	04	210	0,6	1,2	3
0,57	05	210	0,8	1,5	3,8
0,76	06	210	1	2	4,8
0,98	07	210	1,2	2,3	5,6
1,27	09	210	1,5	3	7,2
1,52	11	210	1,9	3,5	8
2,30	13	210	2,6	5	10,3

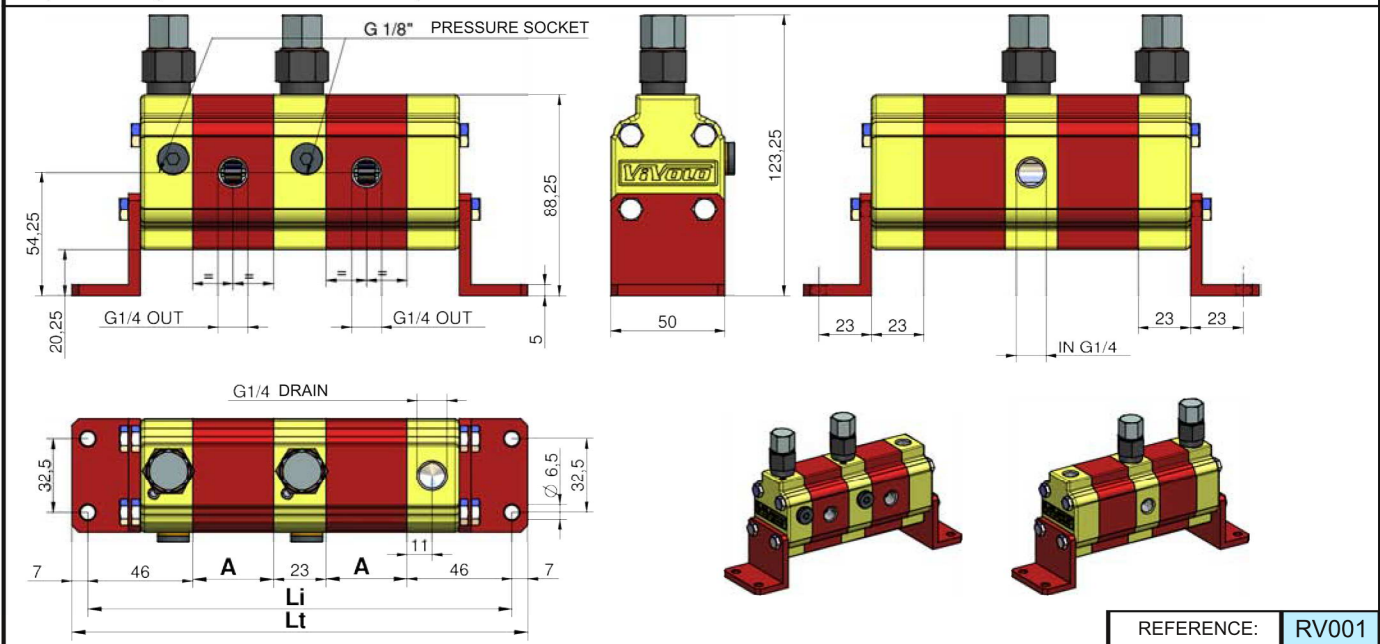

REFERENCE: RV001

Table: 2

Li = Distance between fixing hole centres (single displacement flow divider)

Cm ³ /rev	A	Number of elements														
		2	3	4	5	6	7	8	9	10	11	12	13	14	15	16
0,17	29,3	174,8	227,7	280,6	333,5	386,4	439,3	492,5	545,1	598	650,9	703,8	756,7	809,6	862,5	915,4
0,25	29,9	178	232,5	287	341,5	396	450,5	505	559,5	614	668,5	723	777,5	832	886,5	941
0,45	31,5	180	235,5	291	346,5	402	457,5	513	568,5	624	679,5	735	790,5	846	901,5	957
0,76	34	183	240	297	354	411	468	525	582	639	696	753	810	867	924	981
0,98	35,5	186	244,5	303	361,5	420	478,5	537	595,5	654	712,5	771	829,5	888	946,5	1005
1,27	38	191	252	313	374	435	496	557	618	679	740	801	862	923	984	1045
1,52	40	195	258	321	384	447	510	573	636	699	762	825	888	951	1014	1077
2,30	46	207	276	345	414	483	552	621	690	759	828	897	966	1035	1104	1173

Table: 3 in this table the number of inlets in function of the number of elements are indicated.

Number of elements	2	3	4	5	6	7	8	9	10	11	12	13	14	15	16
"IN" Number of inlets	1	1	2	2	3	3	4	4	5	5	6	6	7	7	8

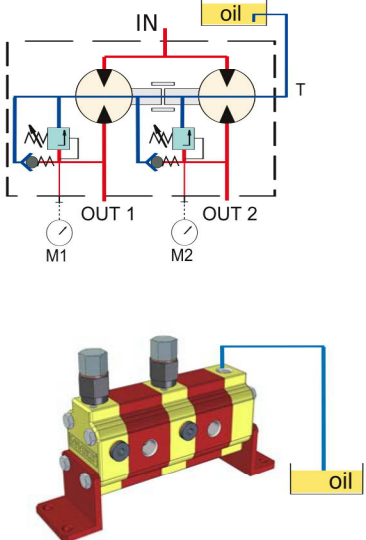
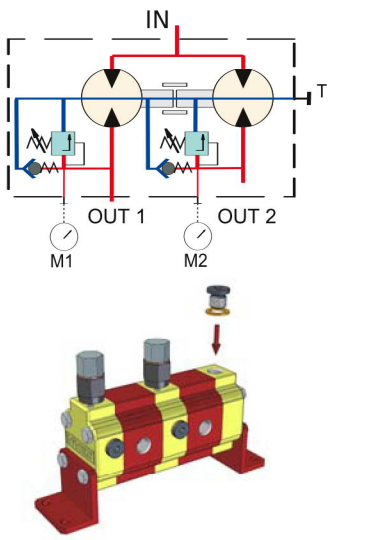
EXTERNAL DRAIN <i>STANDARD SETUP</i>	INTERNAL DRAIN
<p>For the correct functioning of the flow divider, it has to be installed <i>under the oil level</i>. The drain tube has to pick up under the oil level and it has not to aspire air.</p>	<p>To predispose the divider to the internal drain, plug the 1/4 G drain port (T)</p> <p>Note: with this configuration the function of anticavitation valves is annulled</p>
	

In **table 1** the functioning range of single flow divider elements is indicated.

The higher is the feeding capacity (q), the higher is the precision of the flow division, but in opposition there are losses of loading and higher noise. Therefore we suggest to feed the elements with capacities equal or a few superior to the ones indicated in the column "**RECOMMENDED**".

Remember to verify the capacities even in phase of flow reunion.

The pressure indicated are to be considered as maximum of functioning, the flow divider is able to bear peaks of pressure 20 % superior.

How to calculate the "Li" and "Lt" measures of flow dividers:

From **table 2** it is possible to obtain the "Li" measure for flow dividers up to 16 elements with equal displacements; for flow dividers with different elements or with more than 16 elements the "Li" and "Lt" measure have to be calculated by the following formula:

$$Li = [(n-1) \times 23] + 92 + (A1 + A2 + A3 + \dots)$$

$$92 = 46 + 46$$

n = Number of elements of flow divider

A1... An = heights of elements of flow divider

$$Lt = Li + 14$$

$$14 = 7 + 7$$

EXAMPLE: To obtain the measures **Li** and **Lt** of a flow divider with three elements (n=3), **RV-0V 0,98 + 0,76 + 1,27**

Distance between fixing hole centres

$$Li = [(3-1) \times 23] + 92 + 35,5 + 34 + 38 = 245,5 \text{ mm}$$

Total Length

$$Lt = 245,5 + 14 = 259,5$$

In **table 3** the number of inlets in function of the number of elements are indicated.

For flow dividers with many inlets, as they are all communicating it is even possible to use only one of them, by plugging the other ones. We suggest to make full use at least of 1 inlet every 15 l/min capacity.

To obtain errors of division **inferior to 3%** there must be no difference of pressure between the elements superior to **30 bar**. To obtain high precisions the respect of the following parameters is also important:

- Environment temperature: -10°C ÷ +60°C Oil temperature: +30°C ÷ +60°C
- Hydraulic oil based on hlp, hv (din 51524) minerals Oil Viscosity 20 ÷ 40 cSt
- Oil filtering 10 ÷ 25 µ